

The Automatic Detection of Power Theft and Excessive Power Usage in Libyan Electricity Network

Hussien Alalem¹, Abdalla Fadel², Mona Shlibek³, Manal Shlibek⁴

¹Associate Professor - School of Engineering and Applied Science/ Libyan Academy.

²Professor - School of Engineering and Applied Science/ Libyan Academy.

³MSc - Faculty of Engineering / Tripoli University- Engineer at GECOL.

⁴MSc - School of Engineering/ Libyan Academy- Engineer at GECOL.

ARTICLE INFO

Keywords:

*GECOL, Arduino,
Current Sensors,
Voltage Sensors, Relay,
LCD displays.*

ABSTRACT

The General Electric Company Of Libya (GECOL) suffers from power theft phenomenon which is considered as one of the main causes that leads to the load shading problems. This work proposes a system that provides a solution to this problem. Power theft occurs mainly by premises that require a high power consumption like houses, factories and farms. The system automatically detects the illegal users by placing a current sensor on an energy meter that supplies a certain area with electricity. The sensor will assist in the distinction of the illegal consumption. It will be connected to the Arduino to compare the sensed value that represents the actual consumption with the specified consumption value set by GECOL which is stored in the Microcontroller memory. The Arduino is interfaced between the energy meter, current sensor, voltage sensor, and relay. The proposed model is simulated by Proteus as the 1 KW distribution line with three loads. Power system output checks continuously the status of the user connection and displays which line got power theft. Once power theft detected the system is cutting the user connection using relay as a punishment. Then the system is enabling the user connection again. The system can also send a notification message to inform GECOL that there is an additional unexpected consumption detected in that particular energy meter. As a result, GECOL can ensure whether this detected power is authorized by the company.

1. Introduction

In Libya, power theft is a common problem, which results in loss of electrical. The general electricity company of Libyan (GECOL) is the solely company responsible for supplying electricity. Because of the electricity theft, GECOL is facing the frequent problems of load shedding. This power theft phenomenon is definitely needed to be decreased as much as possible. The paper is designed to overcome of this phenomenon. As the ways for stealing the electricity is countless so we can never keep track where exactly the theft has occurred. The proposed system via Arduino kit will automatically calculate the real power consumption from

□ Corresponding Author E-Mail Address: manal.shlibek@gmail.com

houses or buildings in general and compare the real measured data with the assumed consumption data. The Arduino kit attached to energy meter at substation side, which is pole 1, named Master kit. The Arduino kit attached to energy meter at home side, which is pole 2, named Slave kit. The measured data will be transferred via wires from Master kit to Slave kit. The Arduino kit attached to every pole consists of Atmega328 and ACS712 module-current sensor, voltage sensor, and LCD display. The current sensor senses the amount of current that flow through the Slave kit. the sensed reading will be fed to microcontroller/Atmega328 type. Then the Arduino will calculate this sensed reading and send it to Master kit. Depending on current sensor readings at poles 1 and 2, the power theft is detected. The target of the paper is to design a system which automatically detects and control illegal connection of electricity. The simulation was done in this paper by Proteus to design and model of power theft detection and monitoring. Many studies related to electricity theft have been done. In 2013, Pandey, Gill, and Sharma proved that applied Zigbee technology to wirelessly detect the electricity theft, give high efficient and inexpensive method [1]. Moreover, in this year, Patil, Gopal, and Kirtikumar made a real time system to identify wirelessly where exactly the location of illegal tapping is done on a specific distribution line in case a theft is done by tapping. The model was tested for varying amounts of power thefts and also for different types of circuit approximations [2]. By the year 2014, Prashanthi, and Prasad made an organization model to calculate exactly the power consumed in a household consumers from a main source connected on that area at a certain time. This work is detecting the illegal use but not for finding out where exactly it is [3]. In 2015, Dike, et. al. made a system to send a message instantaneously when the theft is done at a certain location [4]. While, two years later, 2017, Prakash, Jebaseeli, and Sindhu identified power theft project using GSM technology. The objective of their project is to design a system which will try to minimize the illegal use of electricity and also reduce the chances of theft. This paper presented the different methods of power theft and the methods to identify the theft occurred in houses and industries [6]. Lastly, in 2018 Saini stated that a primary cause of high distribution losses in India state is a power theft and presented a solution [5]. In the same year, 2018, Khan, Xie, , et. al , designed and Modeled an anti-theft electricity distribution system, their proposed system detects the illegal load and burns it by sending high voltage signal from capacitor bank. The legal load is made safe and uninterrupted during execution of illegal load [7].

2. The Idea of the Proposed System

This paper presented a wire control system that provides a solution of power theft problem by placing the system which will be constructed utilizing the Arduino UNO microcontroller. Arduino with current sensor and voltage sensor will be formed as a number of Master and Slave boards. The proposed system was designed to detect exactly where the probable of both "the power theft" and "the excessive power usage" have occurred in a specific home. They will assist in the distinction of the illegal consumption. However, the Microcontroller will be interfaced between the energy meter and a wire communication network in order to transfer data. A signal will be sent from the consumer side to the substation side in case there is a difference in the compared values. The paper shows the technique of transferring data from Slave board, which is supposed to be connected with consumer side, to Master board, which is supposed to be connected with substation side . Actually, using a communication module to wirelessly send data is easier, more interesting, and reliable. While, sending data using wire style is less expensive. However, sending a notification message to inform GECOL that there is an additional unexpected consumption detected in that specific home or in that particular electricity pole. As a result, GECOL can ensure whether or not this detected power is authorized by the company. Consequently, the power theft once detected the procedures will be taken by

the company. The Master and Slave boards consist of same components (explained in section 2). As each board has a different functionality, the difference between them is the code written in C/ C++ language. This paper shows the code of both boards.

2.1 Functions of Components

2.1.1 Arduino UNO microcontroller

Arduino is an open-source electronics platform based on easy-to-use hardware and software. It's intended for anyone making interactive project. Arduino board senses the environment by receiving inputs from many sensors, and affects its surroundings by controlling lights, motors, and other actuators. Arduino software, you can tell your Arduino what to do by writing code in the Arduino programming language and using the Arduino development environment [8].



2.2 Atmega328:

An Arduino board consist of Atmega328 IC. In this Atmega328 IC we can implement our program [11].



2.3 Voltage Sensor



This module is based on resistance points pressure principle, and it can make the input voltage of red terminal reduce 5 times of original voltage. The max Arduino analog input voltage is 5 V, so the input voltage of this module should be not more than $5\text{ V} \times 5 = 25\text{ V}$. Because the Arduino chip have 10 bit AD, so this module simulation resolution is 0.00489 V ($5\text{V}/1023$), and the input voltage of this module should be more than $0.00489\text{ V} \times 5 = 0.02445\text{ V}$ [10].

2.4 ACS 712 module-current sensor

The ACS 712 consists of a a precise, low-offset, linear Hall sensor circuit with a copper conduction path located near the surface of the die. Applied current flowing through this copper conduction path generates a magnetic field which is sensed by the integrated Hall IC and converted into a proportional voltage. Device accuracy is optimized through the close proximity of the magnetic signal to the Hall transducer. A precise, proportional voltage is provided by the low-offset, chopper-stabilized BiCMOS Hall IC, which is programmed for accuracy after packaging [12].



2.5 Liquid Crystal displays (20 x4)

LCD (Liquid Crystal Display) screen is an electronic display module. It is a flat panel display, electronic visual display. In this paper there is an interfacing of two 20x4 LCDs With Arduino. A 20x4 LCD means it can display 20 Columns and 4 Rows.

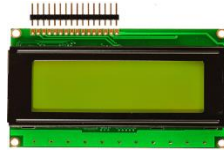

2.6 Power Supply

There are many types of power supply. Most are designed to convert high voltage AC mains electricity to a suitable low voltage supply for electronics.

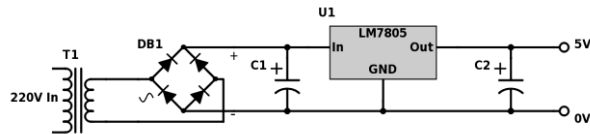

3. Software implementation

The proposed system was designed in Proteus version 8.6. the system takes power supply from the main distribution line as shown in figure1.

Figure 1. shows the main distribution line and power source.

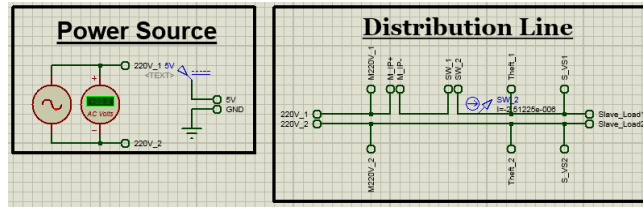

Here, in Proteus simulation, Arduino at consumer side will calculate the electricity theft or calculate the excessive power usage and transmit data via wires to substation side.

Figure.2 Simulation result of Slave Board.

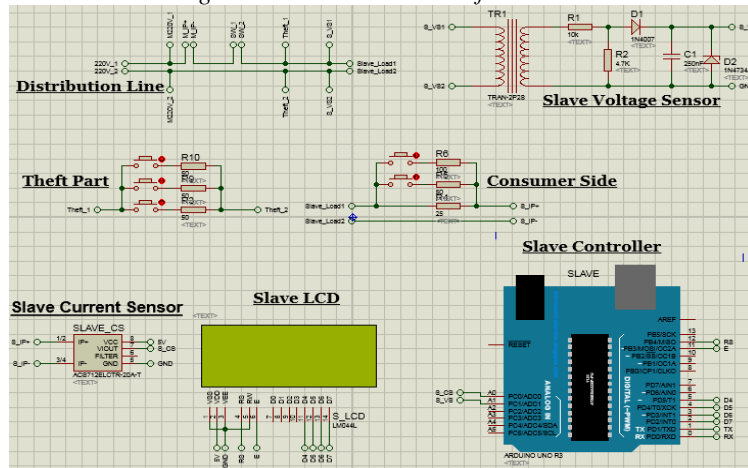

So, the system detects the theft or excessive power usage whenever is occurred in a certain home. It is supposed that at substation side which is pole 1 there is Arduino kit named Master board, and at consumed side which is pole 2 there is Arduino kit as well named Slave board. Transferring data from Arduino at pole 2 to Arduino at pole 1 through wires. Figures 2 and 3 show the Simulation results of both Master and Slave Board respectively. For best accuracy it will be more correct to use external ADC module (it has greater resolution than in-built arduino ADC).

Figure.3 Simulation result of Master Board.

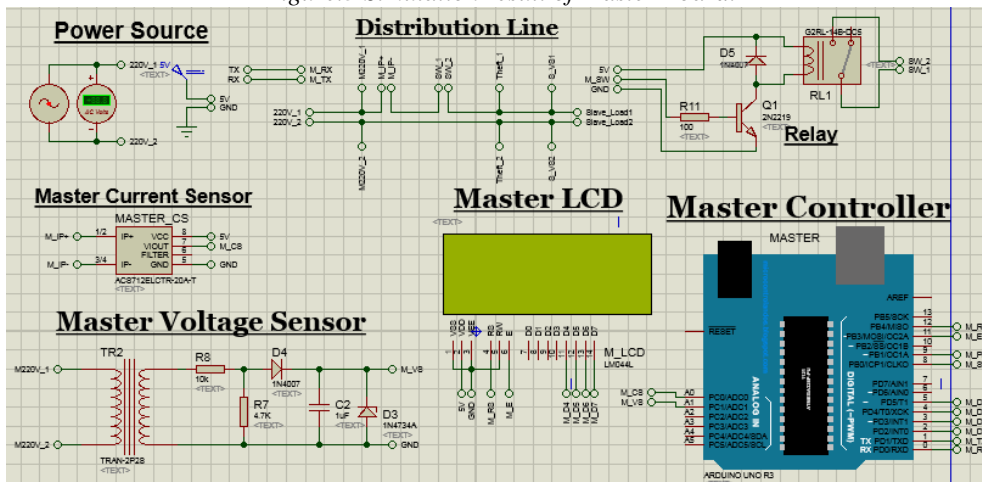
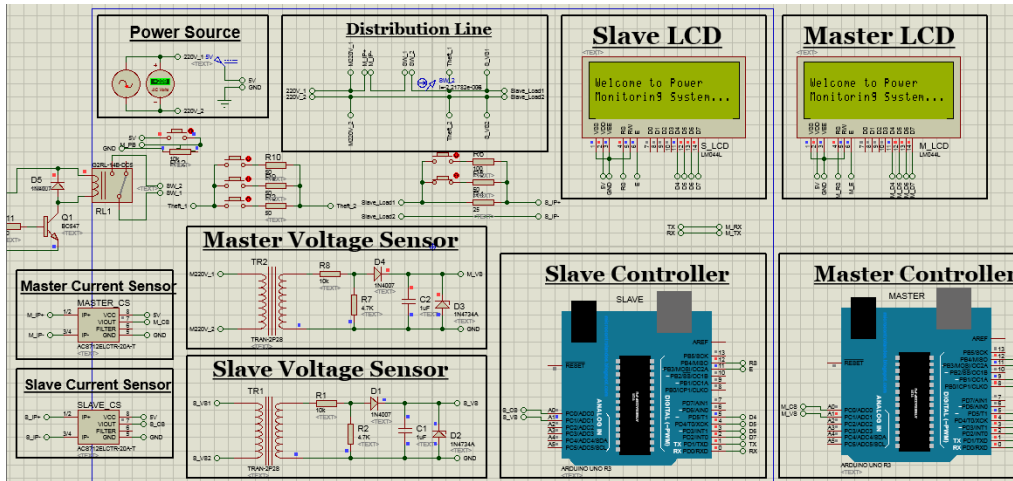
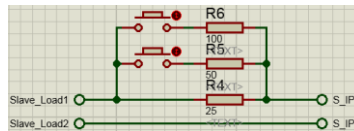

Figure.4 Simulation result of the Power Theft and Excessive Power Usage Detection System.



In the proposed system there are two three resistors, one of them, titled R4 = 25 ohm to represent the normal load and the two other resistor for representing the excessive power usage with two different quantities of load as shown in next figure.



Also, there are another three resistors to represent different quantities of electricity theft as shown in next two figures.



The relay is connected to the Master kit to cutoff the electricity when theft is detected.

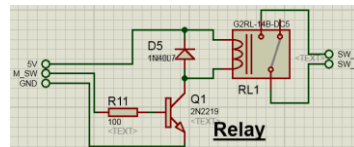

4. Methodology of the Proposed System

This paper discusses four arguments including: Normal Load, Excessive Power Usage, Power Theft Condition, and both Excessive Power Usage with Power Theft have occurred in the same house . The paper shows the distinguish between these four arguments that might be occurred in a specific home.

First Argument: Normal Load Condition

```
void Cal_Eff()
{
  Ef = A-S_C;
  if (Ef>0.1)
  {
    lcd.setCursor(0,3);
    lcd.print("Theft is Detected ");
    delay(500);
  }
  else
  {
    lcd.setCursor(0,3);
    lcd.print("Normal Power Usage ");
    delay(500);
  }
}
```

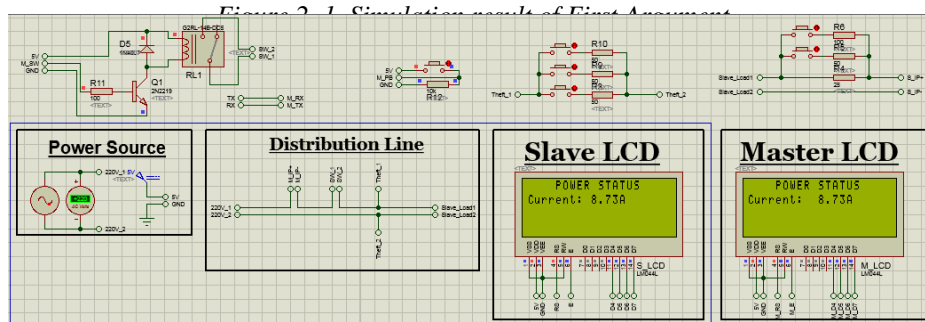
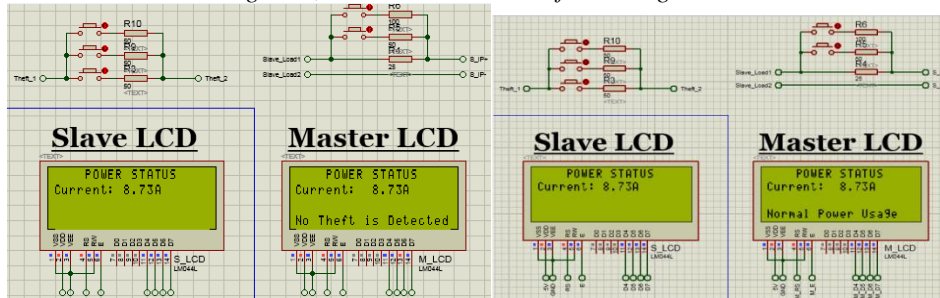

Figure.2, 2 Simulation result of First Argument



Second Argument: Excessive Power Usage Condition

```

if (Ef=0.1)
{
  lcd.setCursor(0,3);
  lcd.print("Excessive Power Usage ");
  delay(500);
}
    
```

Figure.3, 1 Simulation result of Second Argument *Figure.3,2 Simulation result of Second Argument*

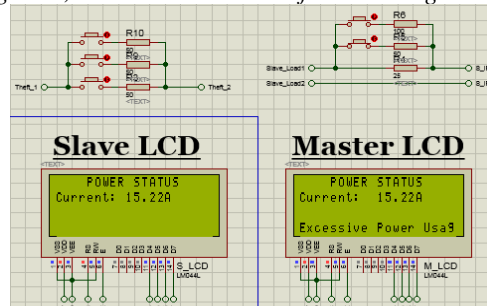
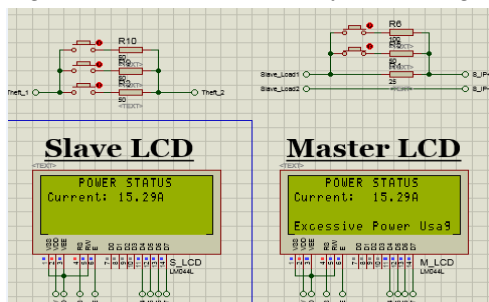

Third Argument: Power Theft Condition

```

if (Ef>0.1)
{
  lcd.setCursor(0,3);
  lcd.print("Theft is Detected ");
  delay(500);
}
    
```

Figure.4 Simulation result of Third Argument

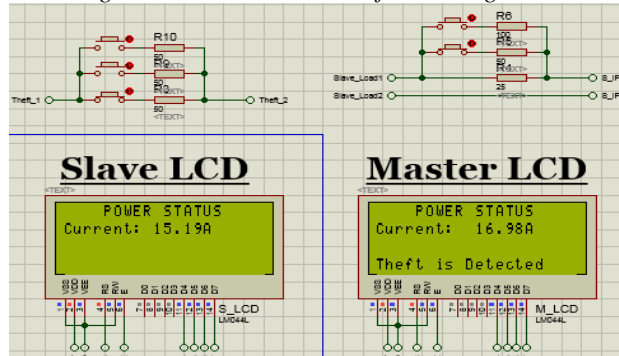

Once theft is detected, the system is cutting off the electricity as shown in figures 5, 6.

Figure.5 Simulation result of Relay's work

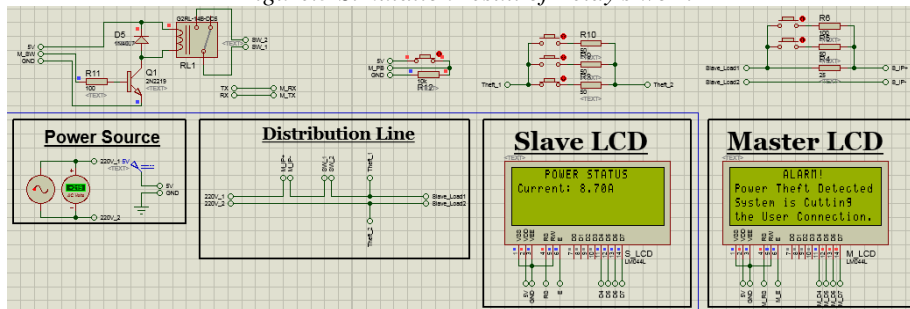
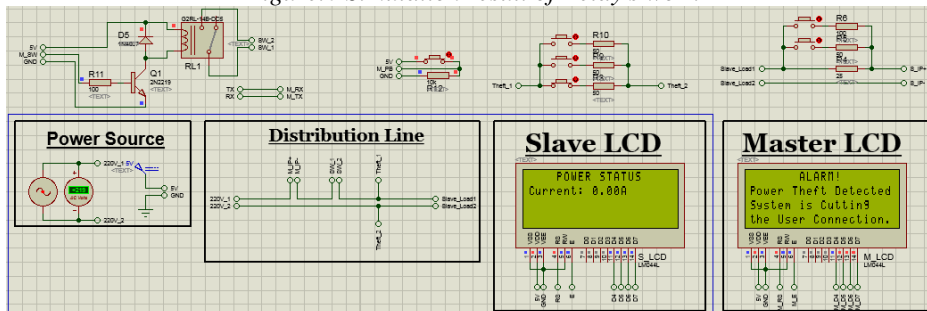

Figure.6 Simulation result of Relay's work



```

if (Serial.available()) // Check the slave Power
{
  S_C = Serial.parseFloat();
  delay(10);
  Cal_Eff(); // Check the efficiency
  if (Ef > 0.1)
  {
    lcd.clear();
    lcd.setCursor(7,0);
    lcd.print("ALARM!");
    lcd.setCursor(0,1);
    lcd.print("Power Theft Detected");
    lcd.setCursor(0,2);
    lcd.print("System is Cutting");
    lcd.setCursor(0,3);
    lcd.print("the User Connection.");
    digitalWrite(Sw_In,LOW);
    delay(3000);
  }
}

```

A switch is connected to the circuit for enabling user connection after the cutting off.

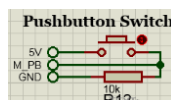



```

if (digitalRead(Pb_In)==HIGH && digitalRead(Sw_In)==LOW) // Check the status of Pushbutton
{
  lcd.clear();
  lcd.setCursor(0,1);
  lcd.print("System is enabling");
  lcd.setCursor(0,2);
  lcd.print("User connection...");
  digitalWrite(Sw_In,HIGH);
  delay(2000);
  lcd.clear();
  lcd.setCursor(0,0);
  lcd.print(" POWER STATUS ");
}
else if (digitalRead(Sw_In)==HIGH) // Check the status of User Connection
{
  Read_Cur(); // Check the Current
  //Read_Vol(); // Check the Voltage
  //Cal_Pow(); // Check the power
  Serial.write('S');
  while (Serial.available()==0)
  {
  }
}

```

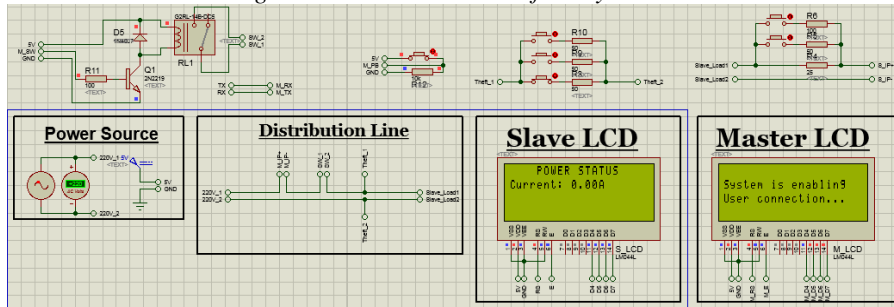
Figure.7 Simulation result of Relay's work



Fourth Argument: Excessive Usage and Power Theft Conditions in the Same House.

```

if (Ef>=0.1)
{
  lcd.setCursor(0,2);
  lcd.print("Excessive Power Usage ");
  lcd.setCursor(0,3);
  lcd.print("Theft is Detected ");
  delay(500);
}

```

Figure.8 Simulation result of fourth Argument

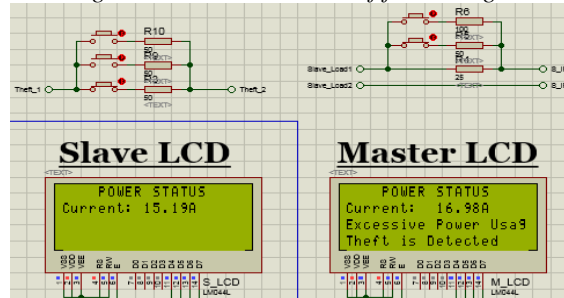

5. The Source Code of Arduino

5.1 The Source Code of Master Board (Arduino Kit)

```

#include <LIQUIDCRYSTAL.H>
CONST INT SW_IN = 8;
CONST INT PB_IN = 9;
CONST INT CU_IN = A0;
CONST INT VO_IN = A1;
CONST INT RS = 12, EN = 11, D4 = 5, D5 = 4, D6 = 3, D7 = 2;
FLOAT FC = 0.225641;
FLOAT A, V, M_P, S_C, EF;
CHAR CH;
INT A, V;
INT M_VPERAMP = 100;
DOUBLE VOLTAGE = 0, VRMS = 0, AMPSRMS = 0;
LIQUIDCRYSTAL LCD(RS, EN, D4, D5, D6, D7);
VOID SETUP()
{ LCD.BEGIN(20, 4);
  SERIAL.BEGIN(9600);
  PINMODE(CU_IN, INPUT);
  PINMODE(VO_IN, INPUT);
  PINMODE(PB_IN, INPUT);
  PINMODE(SW_IN, OUTPUT);
  DIGITALWRITE(SW_IN, HIGH);
  LCD.SETCURSOR(0,1);
  LCD.PRINT("WELCOME TO POWER");
  LCD.SETCURSOR(0,2);
  LCD.PRINT("MONITORING SYSTEM...");
  DELAY(1000);
  LCD.CLEAR();
  LCD.SETCURSOR(0,0);
  LCD.PRINT(" POWER STATUS ");
  VOID LOOP()
  { DELAY(1);
    IF (DIGITALREAD(PB_IN)==HIGH && DIGITALREAD(SW_IN)==LOW)
    // CHECK THE STATUS OF PUSHBUTTON

```

```

{ LCD.CLEAR();
LCD.SETCURSOR(0,1);
LCD.PRINT("SYSTEM IS ENABLING");
LCD.SETCURSOR(0,2);
LCD.PRINT("USER CONNECTION...");
DIGITALWRITE(SW_IN,HIGH);
DELAY(2000);
LCD.CLEAR();
LCD.SETCURSOR(0,0);
LCD.PRINT(" POWER STATUS "); }
ELSE IF (DIGITALREAD(SW_IN)==HIGH)
// CHECK THE STATUS OF USER CONNECTION
{ READ_CUR(); // CHECK THE
CURRENT
//READ_VOL(); // CHECK THE
VOLTAGE
//CAL_POW(); SERIAL.WRITE('S');
WHILE (SERIAL.AVAILABLE()==0)
{ }
IF (SERIAL.AVAILABLE())
{ S_C = SERIAL.PARSEFLOAT();
DELAY(10);
CAL_EFF();
IF (EF>0.1)
{ LCD.CLEAR();
LCD.SETCURSOR(7,0);
LCD.PRINT("ALARM!");
LCD.SETCURSOR(0,1);
LCD.PRINT("POWER THEFT DETECTED");
LCD.SETCURSOR(0,2);
LCD.PRINT("SYSTEM IS CUTTING");
LCD.SETCURSOR(0,3);
LCD.PRINT("THE USER CONNECTION.");
DIGITALWRITE(SW_IN,LOW);
DELAY(3000); } } } }
VOID READ_CUR()
{ VOLTAGE = GETVPP();
VRMS = (VOLTAGE/2.0) *0.707;
A = (VRMS * 1000)/MVPERAMP;
LCD.SETCURSOR(0,1);
LCD.PRINT("CURRENT: ");
LCD.PRINT(A);
LCD.PRINT("A "); }
FLOAT GETVPP()
{ FLOAT RESULT;
INT READVALUE;
INT MAXVALUE = 0;
INT MINVALUE = 1024;
UINT32_T START_TIME = MILLIS();
WHILE((MILLIS()-START_TIME) < 1000)
{ READVALUE = ANALOGREAD(CU_IN);
IF (READVALUE > MAXVALUE)
{ MAXVALUE = READVALUE; }
IF (READVALUE < MINVALUE)
{ MINVALUE = READVALUE; } }
RESULT = ((MAXVALUE - MINVALUE) *
5.0)/1024.0;
RETURN RESULT; }
/* VOID READ_VOL()
{ V = ANALOGREAD(VO_IN);
V = (v * Fc);
LCD.SETCURSOR(10,1);
LCD.PRINT("V: ");
LCD.PRINT(V);
LCD.PRINT("V"); }
VOID CAL_POW()
{ M_P = V * A;
LCD.SETCURSOR(0,2);
LCD.PRINT("M_POWER: ");
LCD.PRINT(M_P);
LCD.PRINT("W "); } */
VOID CAL_EFF()
{ EF = A-S_C;
IF (EF>0.1)
{ LCD.SETCURSOR(0,3);
LCD.PRINT("THEFT IS DETECTED ");
DELAY(500); }
ELSE
{ LCD.SETCURSOR(0,3);
LCD.PRINT("NO THEFT IS DETECTED");
DELAY(500); } }

```

5.2 The Source Code of Slave Board (Arduino Kit)

```

#include <LiquidCrystal.h>
const int Cu_In = A0;
const int Vo_In = A1;
const int rs = 12, en = 11, d4 = 5, d5 = 4, d6 = 3, d7 = 2;
float Fc = 0.228641;
float A, V, P;
char Ch;
int a, v;
int mVperAmp = 100;
double Voltage = 0, VRMS = 0, AmpsRMS = 0;
LiquidCrystal lcd(rs, en, d4, d5, d6, d7);
void setup()
{ lcd.begin(20, 4);
Serial.begin(9600);
pinMode(Cu_In, INPUT);
pinMode(Vo_In, INPUT);
lcd.setCursor(0,1);
lcd.print("Welcome to Power");
lcd.setCursor(0,2);
lcd.print("Monitoring System...");
delay(1000);
lcd.clear();
lcd.setCursor(0,0);
lcd.print(" POWER STATUS "); }
void loop()
{ delay(1);
Read_Cur();
// Read_Vol();
// Cal_Pow();
if (Serial.available())
{ Ch = Serial.read();
lcd.setCursor(19,0);
lcd.print(Ch);
if (Ch == 'S')
{ Serial.print(A); }
delay(10);
lcd.setCursor(19,0);
lcd.print(" "); } }
void Read_Cur()
{ Voltage = getVPP();
VRMS = (Voltage/2.0) *0.707;
A = (VRMS * 1000)/mVperAmp;
lcd.setCursor(0,1);
lcd.print("Current: ");
lcd.print(A);
}
float getVPP()
{ float result;
int readValue;
int maxValue = 0;
int minValue = 1024;
uint32_t start_time = millis();
while((millis()-start_time) < 1000)
{ readValue = analogRead(Cu_In);
if (readValue > maxValue)
{ maxValue = readValue; }
if (readValue < minValue)
{ minValue = readValue; } }
result = ((maxValue - minValue) * 5.0)/1024.0;
}

```

```
return result; }
/* void Read_Vol()
{ v = analogRead(Vo_In);
  V = (v * Fc);
  lcd.setCursor(0,2);
  lcd.print("Voltage: ");
  lcd.print(V);

  lcd.println("V ");}
void Cal_Pow()
{ P = V * A;
  lcd.setCursor(0,3);
  lcd.print("Power: ");
  lcd.print(P);
  lcd.print("W "); } */
```

6. Conclusion

The so-called Smart Grid (SG) has captivated researchers' attention for that it is seen by many to be the key for a sustainable grid future. Smart grid is a terminology that indicates a whole new use of technology applied on the current traditional grid, plus the addition of modern components to the grid for sufficient grid functionality. The paper has considered a number of points: Addition intelligent components to the Libyan power grid to be smart. Reduction of excessive power usage for residential consumer and prevention of power theft could be done using a wire control system. So, GECOL can adjust the electricity that comes into all homes and enforce the user to use a limited amount of electricity depending on the value set by GECOL and wrote in consumer's contract. GECOL can cutoff the electricity from the illegal user.

7. References

- [1] Virendra Pandey, Simrat Singh Gill, Amit Sharma, 2013, Wireless Electricity Theft Detection System Using Zigbee Technology, International Journal on Recent and Innovation Trends in Computing & Communication, ISSN23218169, volume1 Issue: 4.
- [2] Sagar Patil , Gopal Pawaskar , Kirtikumar Patil, April 2013, ELECTRICAL POWER THEFT DETECTION AND WIRELESS METER READING, International Journal of Innovative Research in Science, Engineering and Technology Vol. 2, Issue 4, Copyright to IJRSET www.ijrset.com 1114.
- [3] G. L. Prashanthi, K. V. Prasad, Nov - Dec. 2014, Wireless power meter monitoring with power theft detection and intimation system using GSM and Zigbee networks, IOSR Journal of Electronics and Communication Engineering (IOSR-JECE) e-ISSN: 2278-2834,p- ISSN: 2278-8735.Volume 9, Issue 6, Ver. I, PP 04-08 www.iosrjournals.org www.iosrjournals.org 4 | Page.
- [4] Damian O. Dike , Uchechukwu A. Obiora , Euphemia C. Nwokorie , Blessing C. Dike, 2015, Minimizing Household Electricity Theft in Nigeria Using GSM Based Prepaid Meter, American Journal of Engineering Research (AJER) e-ISSN : 2320-0847 p-ISSN : 2320-0936 Volume-4, Issue-1, pp-59-69 www.ajer.org.
- [5] Sunita Saini, January 2018, ELECTRICITY THEFT–A PRIMARY CAUSE OF HIGH DISTRIBUTION LOSSES IN INDIAN STATE, International Research Journal of Management and Commerce ISSN: (2348-9766), Impact Factor-5.564, Volume 5, Issue 1
- [6] November 2017, International Journal of Advanced Research in Electrical, Electronics and Instrumentation Engineering (An ISO 3297: 2007 Certified Organization) Vol. 6, Special Issue 3, Copyright to IJAREEIE www.ijareeie.com 72, "Power Theft Identification Using GSM Technology". Rhea Prakash, E. Annie Elisabeth Jebaseeli, and Y.S.U.Sindhu. Department of Electrical and Electronics Engineering, Sathyabama University, Rajiv Gandhi Salai, Chennai, India.
- [7] MATEC Web of Conferences 160, 02010 (2018) , EECR 2018., " Designing and Modeling of Automated Anti-theft Electricity Distribution System". Researches Awais Khan1 Wei Xie1, Suhail Aftab Qureshi2, Muhammad Ilyas3, JingChun Lin4 and Guidong Liu4 1 College of Automation Science and Technology, South China University of

Technology, Guangzhou, China, Electrical Engineering Department, UET Lahore, Pakistan 3Iqra International University Peshawar, Pakistan. College of Electrical and Information Engineering, GuangDong Baiyun University, Guangzhou, China.

[8] <https://www.arduino.cc/>

[9] http://www.ekt2.com/pdf/412_ARDUINO_SENSOR_VOLTAGE_DETECTOR.pdf

[10] https://en.wikipedia.org/wiki/RF_module

[11] <https://www.sparkfun.com/datasheets/BreakoutBoards/0712.pdf>

[12] © Winson, 2019/1/21